

The Olis[®] DM 45 Spectrofluorimeter

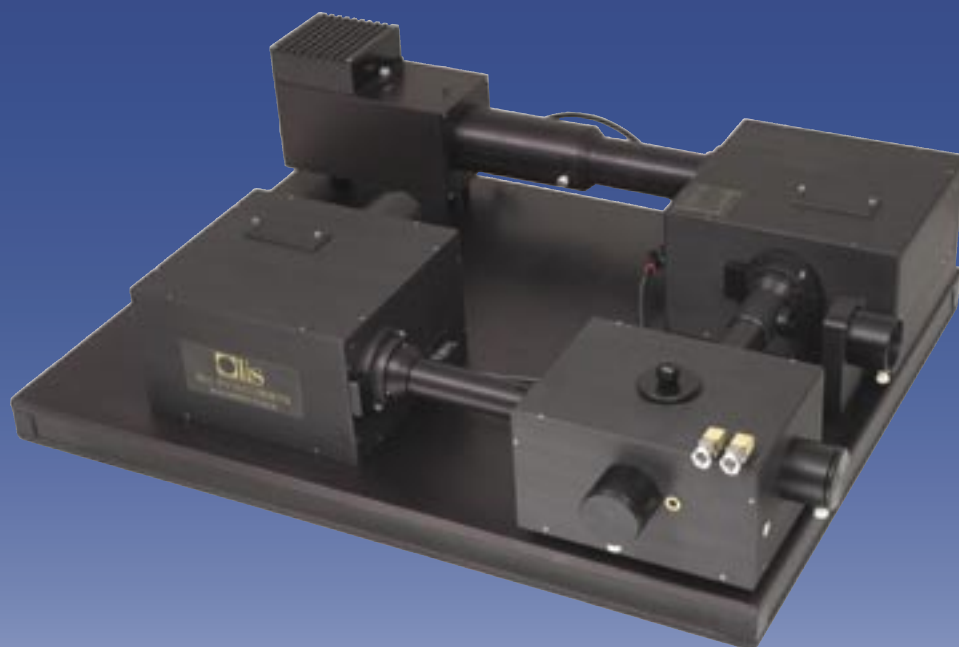

Our classic, compact, and modular line of spectrofluorimeters for highest sensitivity or highest speed studies.

Unlike other sensitive spectrofluorimeters, the Olis DM 45 can be adapted easily and economically for a host of atypical applications, including NIR scanning to 2500 nm, microsecond fixed wavelength acquisition, and dual beam absorbance measurements.

Superb software, easy access to all components, and unbreakable robustness make these instruments ideally suited for both research and teaching laboratories. One can use an Olis DM 45 with solution, solid, and powdered samples in steady-state and time, temperature, and pressure studies.

Each Olis DM 45 is built to order.

- Change one component to make this scanning fluorimeter useful for kinetic studies on a millisecond or microsecond time scale.
- Choose accessories for temperature ramping, titration studies, stopped-flow mixing, and flash photolysis.
- Use our fitting algorithms for 2 or 3D data analysis for better answers.
- And trust the entire workstation to withstand rearranging, novel applications, noxious solvents, and careless handling throughout the years ahead.

Standard Olis DM 45 Components

- 75 watt Xenon arc lamp
- PTI* elliptical reflective lamp housing
- PTI lamp power supply and igniter
- Digital photon counting detector (280-630 nm) for lowest dark count
- Olis single grating excitation monochromator, 40 x 45 mm grating, 250 nm blaze, 1200 lines/ mm.
- Olis single grating emission monochromator, 40 x 45 mm grating, 450 nm blaze, 1200 lines/ mm.
- TMC* honey-combed optical table mount 23" x 35"
- Pentium 3 GHz computer with large LCD and Windows XP
- HP DeskJet printer (latest model)
- Olis SpectralWorks data acquisition/ instrument control software package
- Olis GlobalWorks 2D and 3D data analysis software package
- All requisite Olis electronics
- Surge protected multi-strip outlet

*PTI = Photon Technology, Inc.

*ET = Electronic Tubes, Inc.

*TMC = Technical Manufacturing Corporation

*PMT = photomultiplier tube

Atypical Components to Substitute or Add

- 150 watt Xenon arc or pulse lamp
- 500 KHz 15 bit or 20 MHz 12 bit A/D
- Analog photomultiplier tube(s)
- Photon counting, UV optimized (170-630 nm) or extended range (170-850 nm)
- InGaAs detector(s)
- Stopped-flow mixer
- Dial-in slit width mechanism with 8 slit widths
- Polarization of fluorescence with quartz or sheet polarizers
- Gratings other than standard
- Peltier cell holder, single or 4 position
- Solid sample holder, fixed or variable angle
- Other, such as oxygen electrode, cryogenic flask, custom cuvette holder



Gratings Available to Optimize for Your Spectral Range

Grooves per mm	Disp (nm/mm)	Range	Blaze (nm)	F/#	Resolution (0.5 mm slit)	Resolution (1.24 mm slit)
1200	4	165-800	250	4.2	2	5
1200	4	250-800	350	4.2	2	5
1200	4	300-800	450	4.2	2	5
800	6	350-1200	600	4.2	3	7.5
600	8	400-1600	750	4.2	4	10
450	10	400-2100	900	4.2	5	12.4
300	16	800-3200	1500	4.2	8	20

Raman of Water Numbers

There are various ways to calculate the signal to noise performance of a spectrofluorimeter. The method we use returns ever-better numbers with repetitive scanning.

$$S/N = (\text{Raman Peak} - \text{Base}) / \text{Standard Deviation of Base}$$

Numbers were acquired for both the stock Olis DM 45 with a 75-watt and then with a 150-watt xenon arc lamp. The detector was a photon counter, useful from approximately 170-630 nm. This detector, like the standard one, is rated to 10-100 fold lower dark counts than the extended range version (170-850 nm).

In both cases, 140 data points were acquired from 450-380 nm with 1-second integration time and 5 nm optical band pass in each monochromator. Keep in mind that widening the band-pass has a significant effect on improving S/N.

75 W, single scan	500
150 W, single scan	850
75 W, 10 scans averaged	1300
150 W, 10 scans averaged	2700

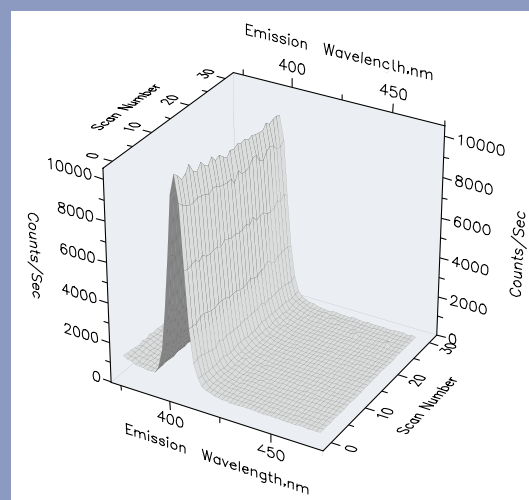

Average of the 30 scans

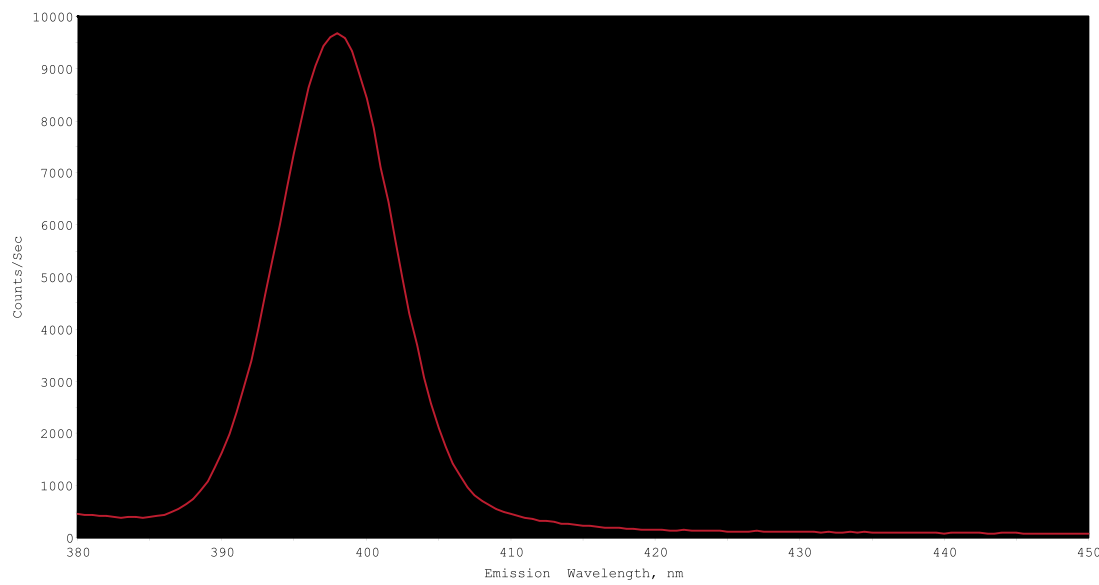

Basic Layout

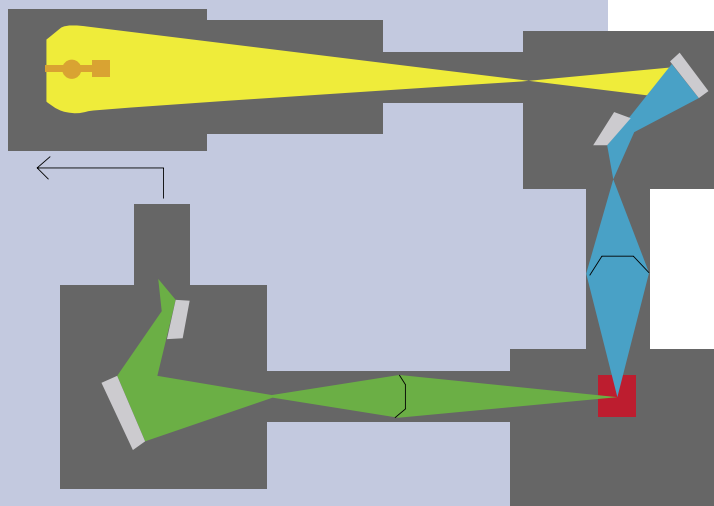

The stylized rendering of the Olis DM 45 optical layout confirms the “classic design” motif: light source, single grating excitation monochromator, sample compartment with single cuvette holder, single grating emission monochromator, and single high sensitivity detector.

Gratings and mirrors are fixed during fixed wavelength measurements. During scanning work, the gratings of each monochromator move independently, such that scanning excitation, scanning emission, and synchronous scanning are supported.



The slits are manual. Standard widths are 0.12, 0.6, 1.24, 3.16, and 6.32 mm, resulting in bandwidths of 0.8 to 40 nm. The gratings and detector are under computer control. To support the widest range of experiments, including very high speed measurements, a continuous illumination lamp is used.



Kinetic Configuration

The Olis DM 45K

For high speed measurements, including stopped-flow mixing and laser/flash photolysis, fast detection and associated detection hardware are substituted for the photon counter, creating the Olis DM 45K.

The Olis DM 45K is fitted with a high speed analog photomultiplier tube and associated 500 KHz or 20 MHz electronics and A/D hardware. Now, instead of a maximum read rate of the photon counter (10 milliseconds), the system supports acquisition rates to 0.005 microseconds. Choose this model, or the components to equip the classic design DM 45 with this high speed capability, when the applications include submillisecond detection.

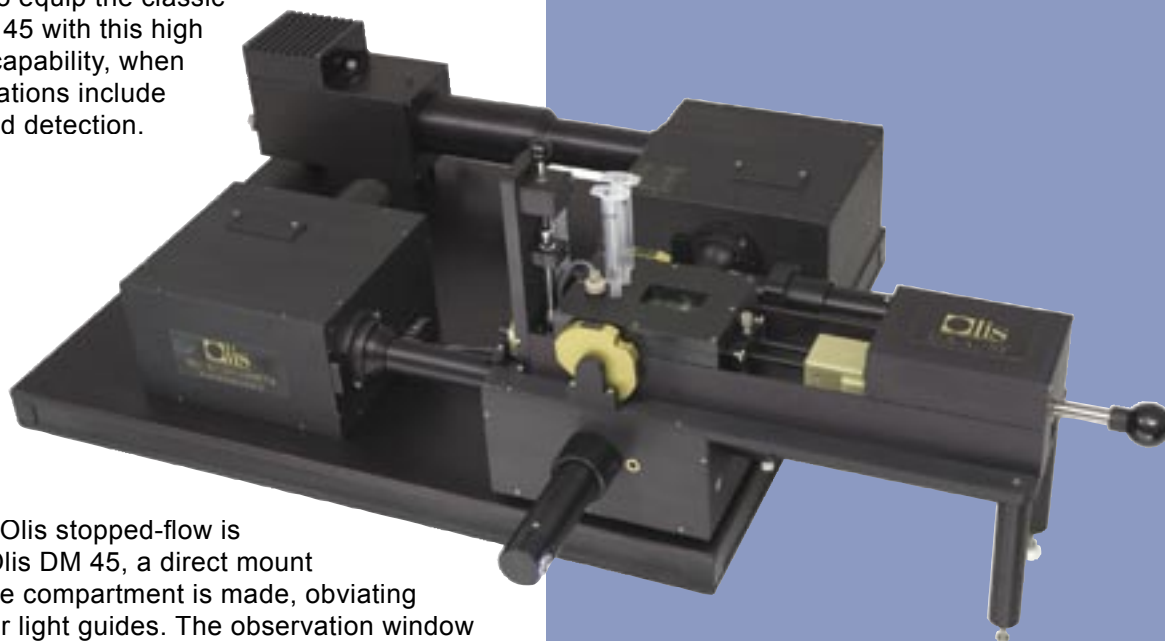

The Olis USA Stopped-Flow

The Olis DM 45 with USA Stopped-Flow

When an Olis stopped-flow is added to an Olis DM 45, a direct mount into the sample compartment is made, obviating the need for light guides. The observation window of the stopped-flow is in the exact position of the 'normal' cuvette. Please request the detailed Olis USA stopped-flow brochure for full details on the four models we offer.

Decades of experience with all types of stopped-flows¹ prepared us to design an Olis model which incorporates what is most utilitarian from them all.

The traditional Ball-Berger mixer and pneumatic drive systems are used, as is the horizontal orientation of the drive syringes². Uniquely, Olis stopped-flows have ceramic valves, rendering them impervious to temperature extremes, corrosives, and gas exchange. Also unique to Olis stopped-flows is a safety interlock system which prevents misfiring of the stopped-flow, ensuring against loss of sample and damage to the hardware or operator.

The Olis software supports the use of any stopped-flow which can send or receive a TTL pulse, so all stopped-flow mixing devices can be interfaced to an Olis DSM 45K with light guides or custom mounting hardware.

¹ In 1969, Olis founder, Richard J. DeSa, published the first paper on computerized stopped-flow spectroscopy with his postdoctoral advisor, Quentin Gibson. The paper, "A Practical Automatic Data Acquisition System for Stopped-flow Spectrophotometry (Computers and Biomedical Research, 1969, 2:494-505) describes the authors' use of computers to analyze and store fast kinetic data. The "stopped-flow spectrophotometer" is introduced and described in "Rapid Mixing: Stopped Flow," Chapter 6, volume XVI in Methods in Enzymology; this chapter is still the best introduction to the technique we have seen and a "must read" reference for everyone new to stopped-flow mixing. Since its founding in the mid-1970s, Dr. DeSa's company has computerized hundreds of stopped-flows, ranging from homemade models to the most sophisticated commercial version.

² Vertical orientation of these syringes has presumed advantages. In practice, horizontal syringes are easier to see and to work with, so we stayed with the classic horizontal orientation.

Temperature Ramping

A standard Olis DM 45 sample compartment includes a single jacketed cuvette holder which can be thermo-regulated with a water bath. At slightly higher cost, a Peltier cell holder can be substituted.

Both devices successfully surround the sample in a jacket of some temperature. Both devices are highly precise and fast, with the Peltier being approximately five-fold faster to reach the target temperature. Both temperature ramping options are rated for wide ranges, spanning at least 25° C to +150° C, and hundredth degree precision.

Olis Single Cuvette Holder

The standard Olis cell holder is machined brass with channeling throughout for fluid circulation around the cuvette from a water bath. This 1 cm² holder removes easily to allow use of the Olis USA stopped-flow, QNW Turret 450, or other sample holder. An optional magnetic stir block fits within the holder. Ports on all sides of the sample compartment support the addition of secondary detectors and/or actinic sources.

Single Peltier Cell Holder

A thermoelectrically controlled cell holder for cuvettes with 1 cm² and shorter pathlengths by Quantum Northwest. Magnetic stirring is built-in. Windows on all four sides support use in fluorescence and absorbance applications. Details on this device are available elsewhere.

The heat exchange unit for the Peltier system is an Olis Heat Exchange Box. The preferred water bath for the water jacketed holder is the analog or digital Julabo™ model F30-C.

Both devices follow identical user-created scripts that include the target temperature and the incubation/equilibrium time at each temperature. The target temperature is reported to the computer by a probe within the sample holders. The incubation time is arbitrary from zero to any number of minutes. After incubation time, the data are acquired. The Olis software then reads the next line of the two column ASCII script to find the next target temperature.

Example of Two Column ASCII Script:

Scripts can be linear, ramping up or down, or any other variant suited to the experiment underway. Comments are allowed anywhere within the file, following a semi-colon.

```
40 10; start at 40° C
50 5
60 1
65 1
70 20
75 0; no dwell time
80 2
```



Single Jacketed Cuvette Holder



Olis-added circulating coil to preferred water bath.



QNW Peltier Cell Holder



Olis Heat Exchange Box

Additional Cuvette Holders

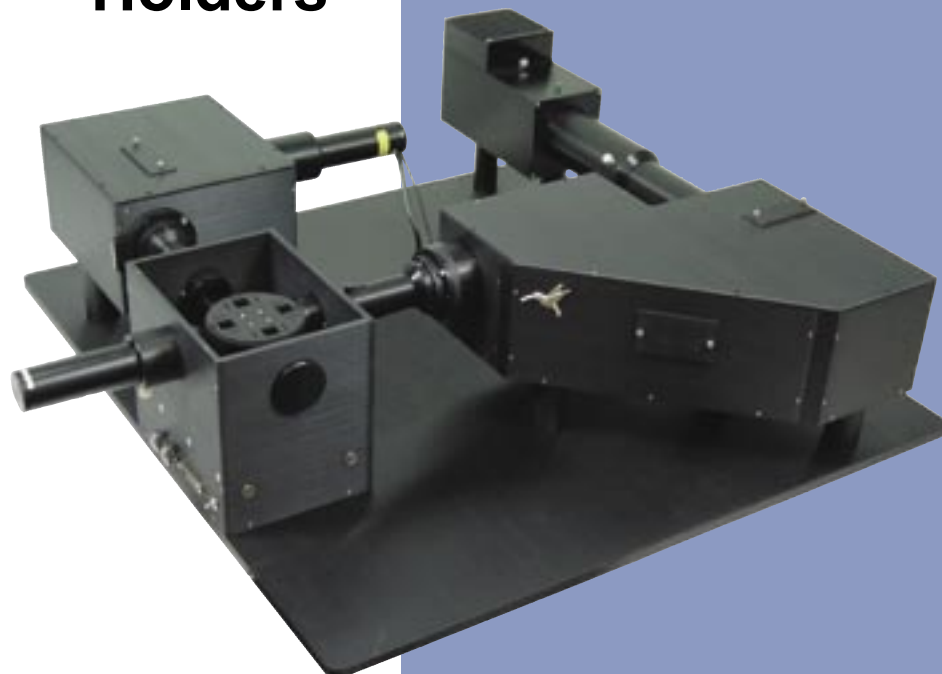

Two 4-position cell holders are available. Both require a larger than standard sample compartment, so prices for these accessories include this different chamber. In the case of the Peltier unit, the entire Olis DM 45 must be raised several inches, so that legs are mounted underneath the lamp housing and monochromators. Here, the Olis DM 245 spectrofluorimeter – a variant of the Olis DM 45 with a double grating Hummingbird monochromator replacing the standard Olis single grating monochromator – is shown with the 4-position Peltier in its elevated chamber.

Olis 4-Position Jacketed Holder

Our four position cell holder has a linear mechanism with diagonal geometry. The 1 cm² cell holders have apertures on all four sides to support use in both absorbance and fluorescence modes. Magnetic stirring blocks can be added. Temperature control is achieved with a Julabo digital bath or other source of circulating fluid. A reference cell position can be added for dual beam absorbance or fluorescence work when the optional beam splitter is in place.

QNW 4-Position Peltier in custom chamber

This thermoelectrically controlled four position cell holder by Quantum Northwest (www.QNW.com) is for fastest temperature ramping of up to four samples simultaneously. The turret moves in a single direction circular position. Magnetic stirring is provided in all positions. The geometry supports only fluorescence detection applications. Details on this device are available elsewhere.

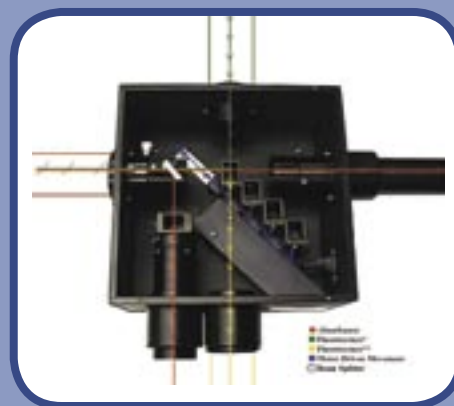

Olis 4-Position Jacketed Holder



QNW 4-Position Peltier in custom chamber

Pressure and Titration Accessories



High Pressure Cell Holder

The HPCell™ High Pressure Cell System

Reach pressures up to 4000 bars (58,000 psi) with sapphire windows and up to 3000 bars (43,000 psi) with quartz windows (specify windows at time of purchase) by adding the ISS High Pressure Cell. The system includes the pressure cell, the pump and the Olissoftware for system control and data acquisition.

Olis Automatic Titrator

The Olis titrator is a two, three, or four syringe device for mixing user specified volumes of protein and titrant, enzyme and inhibitor, etc., for fully automated introduction of freshly mixed solutions into the measuring cuvette. The solutions can be degassed for anaerobic work or they can be temperature regulated for thermal studies. To minimize photolysis effects, the solutions can be kept in the dark other than during data acquisition. And no magnetic stirring is required for homogenous sample preparation, so that all pathlength cuvettes are suitable.

Enzyme Assay Device/ 4 Syringe

In this model, volumes from syringes 1, 2, and 3 are mixed in the mixing valve and volume of syringe 4 is mixed further down the line, nearer the measuring cuvette. Thus, the appropriate mixture of inhibitor, substrate and buffer is prepared and then, right before the mixture shoots into the measuring cuvette, the reactant—the enzyme—is added, too. After the scan, instead of the mixture being withdrawn into any of the syringes, it is forced out of the system by a flush of buffer. Thus, the measuring cuvette is thoroughly rinsed with buffer between each run.

There is a great deal of flexibility in our designs, both explicitly and implicitly. Volumes added can be anything from 0.0 or 0.0001 of the syringe volume to 100% of it. Mixing can be done any number of times. Changing syringes from one size to another is a 5 minute operation. And any number of scans can be made of each dilution.

- Use for automated preparation of two, three, or four solutions.
- Standard syringe volumes are 2.5 mL, with 0.5, 1, 5, and 10 mL also available.
- Automate simple protein denaturant titration or complex enzyme, substrate, inhibitor, and buffer mixtures with our titration accessories, both two and four syringe versions.

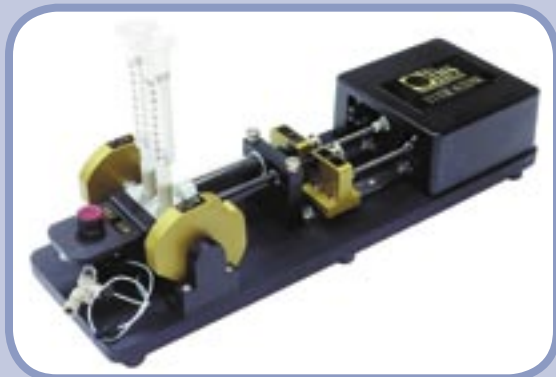

Olis Automatic Titrator



4 Syringe Titrator

NIR Wavelength

Optimize the emission or excitation monochromators for full NIR scanning to 1700 or 2600 nm by choosing NIR blazed gratings and InGaAs detectors.

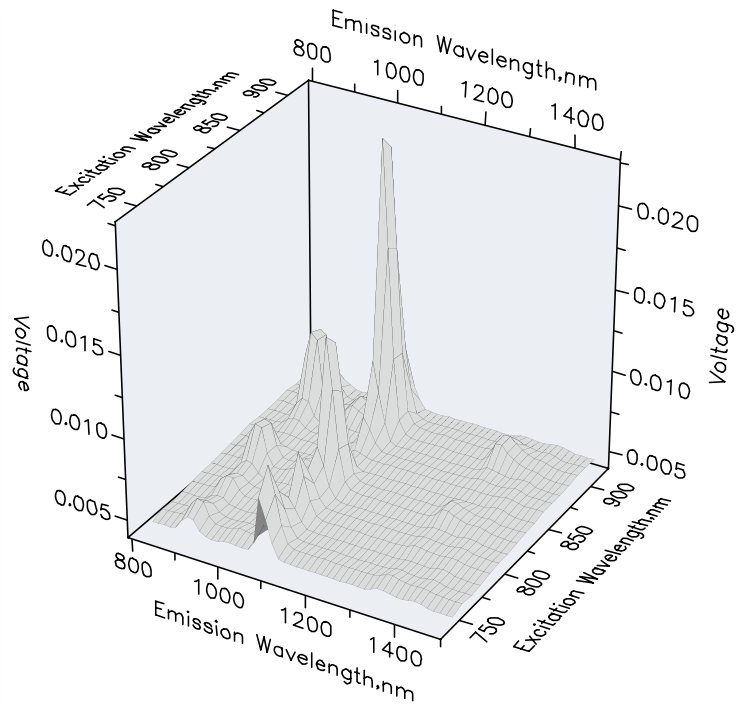

Three-dimensional data acquired as the Olis DM 45 scanned both the excitation and emission wavelengths to produce this profile of Nd doped glass.

Fluorescence produced by ATX (which contains complexed lanthanide ions)

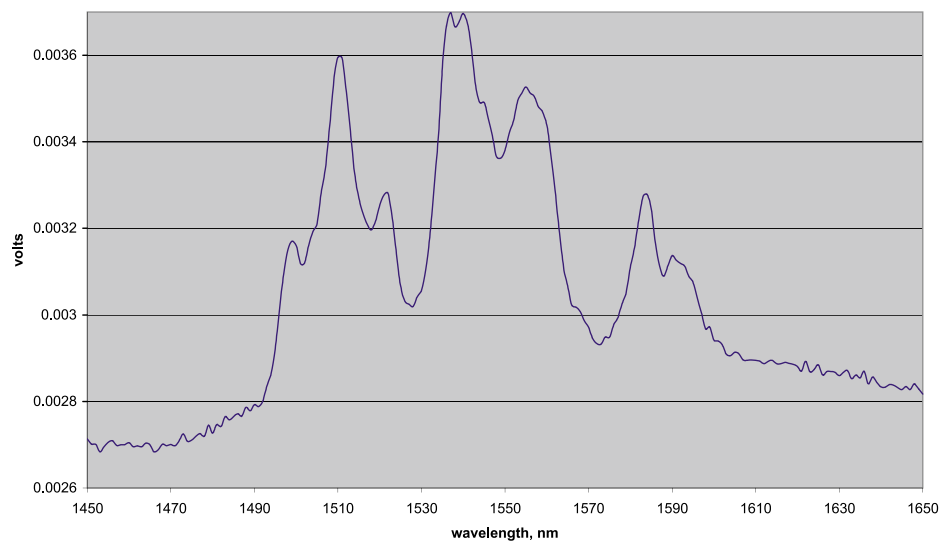

All Olis Instruments operate with extremely similar versions of Olis SpectralWorks™ software

Data Processing with Olis SpectralWorks Software

Olis SpectralWorks software includes a long list of useful data processes for single datasets including:

- Apply Constant
- Average Scans Within Dataset
- Average Points
- Convert Volts to Absorbance
- Correct Fluorescence
- Convert CD Units
- Dilution Correction
- Derivative
- Digital Filter
- Fourier Transform
- Integration
- Interpolate
- Normalize
- Peak Finder
- RC Filter
- Reverse X Axis Data Array
- Reverse Y Axis Data Array
- Reverse Axes Data Array
- Swap Axes
- Synthesize New Dataset
- Trim Points
- Take Reciprocal
- CDSSTR
- CONTINLL
- SELCON3
- Inverse Spectrum

This composite image shows the spectrum (upper left), the data processing choices (lower left), selection of 1-4 order derivative (upper right), and the final screen with the second derivative calculated and plotted.

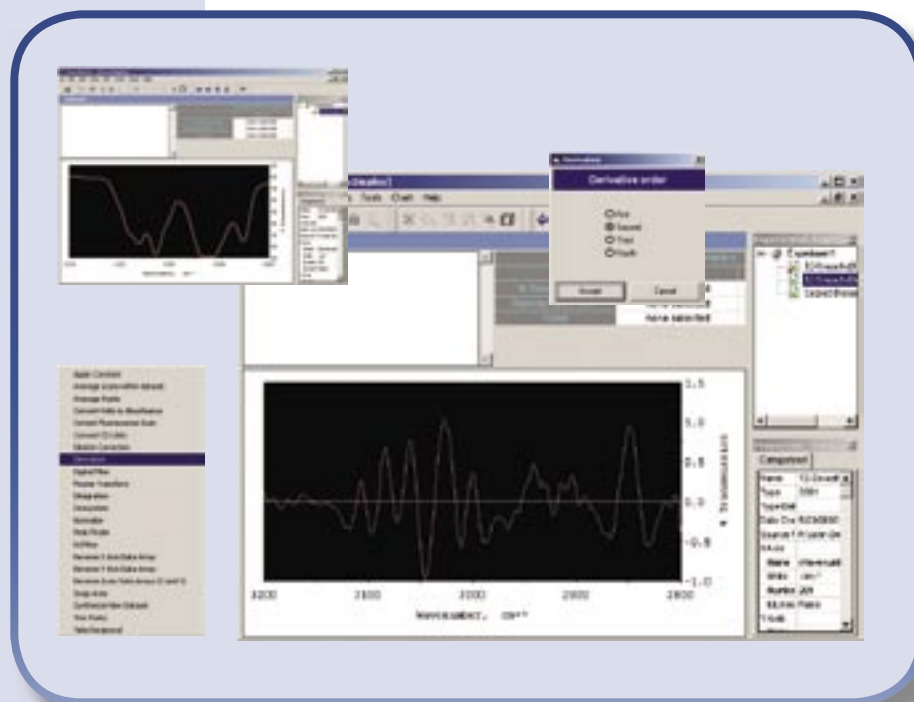

Olis SpectralWorks software also includes data processes for working with multiple datasets:

- Add Selected Datasets
- Subtract Selected Datasets
- Average Selected Datasets
- Multiply Selected Datasets
- Apply Constant
- Normalize
- Concatenate
- Anisotropy
- Polarization
- Corrected Scans
- Build 3D Dataset from 2D

Data Acquisition Screens from the Olis SpectralWorks software



Choose either polarization or anisotropy modes of detection (other collection modes based on accessories activated).



Repeated scans can be taken as a function of time, temperature, or concentration of reagents. Any number can be collected and retained or accumulated and averaged.



The X- and Y-axes can be changed during data collection with an option to override autoscale.



Photon counting detectors, photomultiplier tubes, and InGaAs detectors are available for use, optimizing the instrument for specific speed, sensitivity, and wavelengths.

"I have the Olis DM45 spectrofluorimeter in my lab and have found it to be very useful in my research, most of which is conducted with undergraduate research students. We use it routinely to measure both protein fluorescence and to conduct both steady state and transient kinetics studies (with the aid of the stopped-flow accessory) and have found that it produces reproducible and reliable data. It is simple to operate and the associated software offers powerful data analysis tools. I am pleased that my undergraduate students have no trouble using the instrument. Perhaps the best part of the instrument is the tremendous support that I have received from the Olis technical staff. On the few occasions that I have encountered technical problems, Olis has been able to resolve the problems in a very timely manner, often within hours of the time that I contacted Olis for help. I couldn't be happier with my instrument and more importantly, with Olis!"

Henry A. Charlier, Jr., Ph.D.
Boise State University

"The DM45 is a very sensitive instrument with high signal stability. Even with fast acquisition times, good signal to noise ratio can be achieved both in scanning as well as assay modes. The user-friendly data acquisition software is very easy to learn and provide quick access between emission scan, excitation scan and assay modes. Data analyses options are quite comprehensive, 2D as well as 3D figures can be created easily. Transferring the data as an ASCII file and analyzing it using Excel, etc. is another option provided by the software. Finally, the fitting algorithms add to the power of data analysis."

F. Peter Guengerich, Ph.D.
Vanderbilt University Medical Center

"...But, you know, if anybody asked me whether I would recommend buying an Olis, I would say yes. . . . I like it better than any other fluorimeter I have used, so does my young colleague who is doing all the work with it. . . . We have had a lot of teething problems, but are now using the instrument on a daily basis . . . we feel we are in good hands, have an effective dialogue with your colleagues, and are moving towards an ideal state where, firstly, everything works as it should, and secondly, we have a pretty good working knowledge of the machine itself, my colleague of the software, I of the hardware, as an investment against any possible problems in the future. That's not a state we are in for most of our instruments."

Jonathan C. Howard, Ph.D.
University of Cologne



For more information on this and other Olis products:

Visit www.olisweb.com

Write sales@olisweb.com

Call **1-800-852-3504** in the US & Canada
1-706-353-6547 worldwide